



**FLORIDA BUILDING CODE  
ENGINEERING EVALUATION REPORT**

Date | 2023-10-06  
File No. | 0072-1-2-5953  
For | Cedar Valley Manufacturing, Inc.  
Address | 943 San Felipe Rd, Hollister, CA 95023-2807

**Subject**

Cedar Valley Shingle and Mansard exterior cladding panels.

**Evaluation Scope**

This report is provided to assist registered design professionals and building officials in the United States with determining compliance to the performance objectives in the named building codes. The product(s) described herein have been evaluated to the 2023 Florida Building Code (FBC) and Residential Code (FBC-R).

**CSI DIVISION:** 07 00 00 THERMAL AND MOISTURE PROTECTION  
**SUBDIVISION:** 07 46 00 Siding

**FBC CATEGORY:** Panel Walls  
**SUB-CATEGORY:** Siding

**CODE SECTIONS AND STANDARDS**

FBC Section	Description	Referenced Standard or Code Section <sup>1</sup>	Year
1403.2	Weather Protection	ASTM E331	2009
1403.3	Wind Resistance	FBC Ch 16	-
1405.2	Weather Protection	FBC Ch 16	-
1609.1.1	Determination of Wind Loads	ASCE 7	2022
1609.1.3	Testing to Allowable or Nominal Loads	ASCE 7	2022
1709.2	Load Test Procedures Specified	ASTM E330 (Ch 35)	2014
FBC-R Section	Description	Referenced Standard or Code Section <sup>1</sup>	Year
R703.1.1	Water Resistance	ASTM E331	2009
R703.1.2	Wind Resistance	ASTM E330	2014
R703.1.2	Wind Resistance	Tables R301.2(2) & R301.2(3)	-
Table R703.3(2)	Component and Cladding Loads	-	-

1. Only the applicable reference standards and code sections cited in the main body text are listed. (-) indicates that the main body text covers the full explanation of the objective.



**COMPLIANCE STATEMENT**

It is the opinion of Boca Engineering Co. that Cedar Valley Shingle and Mansard exterior cladding panels, when installed as described in this report, has demonstrated compliance with the listed sections of the 2023 Florida Building Code (FBC) and Residential Code (FBC-R). Design and performance information can be found in the Product Evaluation section this report.

This report has been prepared and reviewed on behalf of Boca Engineering Co. by:

Christopher Bowness, P.Eng., P.E.

2023-10-06

Issue Date

12-31-2026

Expiry Date

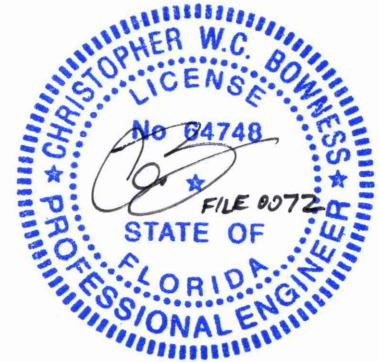

**EVALUATION REPORT TERMS**

1. This report is a general evaluation of the building code section requirements as identified and applies only to the samples that were evaluated. It does not imply any endorsement or warranty, nor that the signatory Engineer is the Designer of Record of any construction project for which the information is used.  
Rule 61G20-3 (17)(a) Definition: Evaluation report means a report based upon testing or comparative or rational analysis, or a combination thereof, from an approved product evaluation entity or a licensed Florida professional engineer or architect indicating that the product was evaluated to be in compliance with the Code or the intent of the Code and that the product complies with the Code or is, for the purpose intended, at least equivalent to that required by the Code.
2. This Evaluation Report expires Dec. 31, 2026, open to renewal. Up to the renewal date, the report is valid until such time as the named product(s) changes, the Quality Assurance Agency changes, or provisions of the Code that relate to the product change.

**CERTIFICATION OF INDEPENDENCE**

1. Boca Engineering Co., it's employees and shareholders, do not have, nor do they intend to or will acquire, a financial interest in any company manufacturing or distributing products that they evaluate.
2. Boca Engineering Co. is not owned, operated, or controlled by any company manufacturing or distributing products that they evaluate.

**Contents**

	<b>pg.</b>
Product Evaluation	3
Attachments	6
ATTACHMENT 1: GENERAL ASSEMBLY DETAILS	6
ATTACHMENT 2: WIND PRESSURE AND WIND SPEED TABLES	7
ATTACHMENT 3: ASSEMBLY DIAGRAMS	8



---

## Product Evaluation

### 1.0 PRODUCT DESCRIPTION

Cedar Valley Shingle and Mansard panels are used as an exterior wall cladding. Panels are factory assembled, consisting of vertical or mixed grain No. 1 grade Western Red Cedar tapered shingles secured to 11/32" Exposure 1 plywood. A layer of coated fiberglass felt is placed between the shingles and the plywood panel. The shingles are secured to the plywood panel with exterior glue and galvanized staples.

Panels are 96" long and may be field cut to width. Shingles are placed with an exposure of 5.3", 7-1/8", or 14".

### 2.0 INSTALLATION

- 2.0.1. The cladding systems as described in Section 1 shall be installed in accordance with the manufacturer's installation instructions, the 2023 Florida Building Code, and are subject to the limitations stated within this report. The requirements specified in this report govern over any conflicts with the manufacturer's instructions.
- 2.0.2. Wall framing construction and water resistive barrier for which the siding panels are to be installed over shall be designed and installed in accordance with the 2023 Florida Building Code.
- 2.0.3. For the general assembly details, see ATTACHMENT 1: General Assembly Details.

### 2.1 Manufacturer's Published Installation Instruction Documents

- 2.1.1. 1 Course Cal Stack Hurricane Blind Nail CVAI – 203.
- 2.1.2. 1 Course Mansard Panels CVAI – 207.

### 3.0 CODE SECTIONS REVIEW

<u>FBC Section</u>	<u>Description</u>
1403.2	<b>Performance Requirements, Weather Protection</b> A representative wall construction assembly with Cedar Valley Shingle and Mansard siding panels installed on wood frame construction with a water-resistive barrier and flashing as described in this evaluation report has been tested to ASTM E331, under the conditions of FBC 1403.2 Exception 2. The tested assembly meets the criteria and conforms to this code section.
1403.3	<b>Structural</b> The structural design loads described in this report are in accordance with Ch 16 of the FBC.
1405.2	<b>Installation of Wall Covering, Weather Protection</b> The plywood backing and wood shingle veneer of the cladding panels meet the minimum material thickness of weather coverings as required in Table 1405.2.
1609.1.1	<b>Determination of Wind Loads</b> Wind load pressure (psf) applied to the cladding for use with the design values published in this report is determined in accordance with Chapter 30 of ASCE 7-22.
1609.1.3	<b>Testing to Allowable or Nominal Loads</b> The ASD conversion factor of tested allowable loads has been applied in accordance with this code section.



**1709.2 Load Test Procedures Specified**  
The load test procedure and load factors in FBC referenced standards ASTM E330 were used.

**FBC-R Section      Description**

**R703.1.1 Water Resistance**  
Same as this report commentary to FBC 1403.2.

**R703.1.2 Wind Resistance**  
The load test procedure and load factors in FBC referenced standards ASTM E330 were used to determine allowable wind pressure.

**R703.1.2 Wind Resistance**  
Allowable wind pressure values published in this report may be used with Tables R301.2(2) and R301.2(3) for walls using an effective wind area of 10 square feet.

**4.0 LIMITATIONS**

- 4.0.1. This Evaluation is for the base code requirements of the building system as addressed in this report. In some building applications, additional performance objectives may be required by Code which must be addressed in the building design for those specific cases.
- 4.0.2. Design calculations, drawings, and special inspections are to be furnished for building projects by registered professionals as required by the respective jurisdictional authorities and Codes.
- 4.0.3. This Evaluation Report is for Cedar Valley Shingle and Mansard panels for use in non-HVHZ jurisdictions, as installed in a wall or mansard roof assembly.
- 4.0.4. The installation details for each assembly evaluated for determining the maximum design wind uplift pressure are described in *ATTACHMENT 1: GENERAL ASSEMBLY DETAILS*, and limited to those conditions.
- 4.0.5. Materials used as components in the assemblies shall comply with the FBC, and, if applicable possess the required product approval certification and labeling.
- 4.0.6. Building framing and wall sheathing must be designed and installed in accordance with Code for capability of supporting the imposed loads, including but not limited to positive and negative wind loads.
- 4.0.7. The minimum mansard roof slope of Assembly 5 is 60° to the horizontal. Water from the main roof is not to flow on to the shingle panels.
- 4.0.8. Panels are a veneer cladding; they are not to be used as a nailing base or as structural sheathing.
- 4.0.9. Scope of evaluation does not include siding applications where interior or exterior wall Fire Resistance rating is required.
- 4.0.10. In accordance with FBC 1406.2, Cedar Valley Shingle and Mansard panels on buildings of Type I, II, III, and IV construction shall:
  - i. not exceed 10% of an exterior wall surface area where the fire separation distance is 5 feet (1524 mm) or less, and
  - ii. be limited to 40 feet (12 192 mm) in height above grade plane.
- 4.0.11. Clearance between exterior wall coverings and final earth grade on the exterior of a building shall not be less than 6 inches, in accordance with FBC 1403.8.



## 5.0 FIRE CLASSIFICATION

Fire classification has not been evaluated.

## 6.0 QUALITY ASSURANCE ENTITY

The products evaluated in this report are surveyed at the approved manufacturing locations with third-party quality assurance inspections in accordance with Rule 61G20-3 by QAI Laboratories, Inc.

## 7.0 MANUFACTURING PLANTS

Manufacturing and labeling location(s): Hollister, CA.

## 8.0 LABELING

Labeling shall be in accordance with the requirements of the FBC, and the Accredited Quality Assurance Agency.

## 9.0 REFERENCE TESTING AND EVALUATION DOCUMENTS

<u>Entity</u>	<u>Entity Accreditation<sup>1</sup></u>	<u>Standards</u>	<u>Report No.</u>	<u>Issued Date</u>
Cerny and Ivey Engineers, Inc.	IAS TL-298	ASTM E330	25261	2006-09-27
Cerny and Ivey Engineers, Inc.	IAS TL-298	ASTM E330	26234	2006-12-14
Cerny and Ivey Engineers, Inc.	IAS TL-298	ASTM E331	22270-5	2002-11-01
QAI Laboratories	FBC QUA7628	Quality Assurance	CJ1064	2023-09-26

1. Testing, certification, evaluation, and inspection agencies referenced have been verified to be accredited by the International Accreditation Service ([www.iasonline.org](http://www.iasonline.org)) for the applicable scope, in good standing on the date of the evaluation, in accordance with ISO 17025 and ISO 17020 international standards for testing and inspection bodies.



## Attachments

### ATTACHMENT 1: GENERAL ASSEMBLY DETAILS

**Wall Framing:** Spruce-Pine-Fir (SPF) No.2 2x4 (or better) dimensional lumber spaced at 16" on center, installed per Code. Members may be substituted with i) any larger section dimension of the same material, and/or, ii) any species/grade of 0.42 specific gravity or greater. Framing design and installation are the responsibility of the engineer or architect of record for the project of installation.

**Wall Sheathing:** Minimum wall bracing (sheathing or lumber), installed per Code attached to the wall framing to resist the required lateral design pressures.

**Water-Resistive Barrier, Flashing:** Water-resistive barrier and flashing installed per Code.

**Shingle Panel Anchorage:** The shingle panels must be secured to the wall framing using D.H. Maze Company Stormguard S-227-A ring shank (13 Ga., 3/8" diameter head, length per detail), corrosion resistant nails. Assemblies were tested with nominal 1/2" wall sheathing. If installed sheathing thickness exceeds 1/2", fastener length to increase to provide equal penetration depth in to stud. The nail head is to be flush with the surface of the shingle panel. Nails must not be overdriven. The shingle panels must span at least one wall stud spacing. Vertical edge joints are to be staggered and land on studs.

**Clearance:** A minimum 6" clearance between wood panel and exterior earth surface or 2" clearance from exterior concrete surface is required per FBC Ch 23.

**Table 1: Assembly Installation Design Pressure Details<sup>1,2,3</sup>**

Assembly No.	Type (Single course)	Exposure	Shingle Butt Thickness	Fastener	Allowable Design Pressure (psf) <sup>4,5</sup>
1	Coastal Panel	5.3"	1/2"	<b>One (1)</b> fastener per wall stud; 1/2" from vertical edge; 1-1/2" from top edge; min 1-3/4" length; min 3/4" wood frame penetration.	82.0
2	Coastal Panel	5.3"	5/16"	<b>One (1)</b> fastener per wall stud; 1/2" from vertical edge; 1-1/2" from top edge; min 1-3/4" length; min 3/4" wood frame penetration.	82.0
3	Coastal Panel	7-1/8"	5/16"	<b>One (1)</b> fastener per wall stud; 1/2" from vertical edge; 1-1/2" from top edge; min 1-3/4" length; min 3/4" wood frame penetration.	65.9
4	Vent Panel <sup>6</sup>	7-1/8"	5/16"	<b>One (1)</b> fastener per wall stud; 1/2" from vertical edge; 1-1/2" from top edge; min 2-1/2" length; min 1" wood frame penetration.	83.2
5	Mansard and Sidewall Panel	14"	3/8"	<b>Two (2)</b> fastener per wall stud; a. 1/2" from vertical edge; 1-1/2" from top edge; b. 1/2" from vertical edge; 3" from bottom edge; min 2-1/2" length; min 1" wood frame penetration.	76.3

**Table 1 Notes**

- All component material and installation specifications listed in ATTACHMENT 1: GENERAL ASSEMBLY DETAILS must be followed to use this table.
- Further assembly details provided in ATTACHMENT 3: ASSEMBLY DIAGRAMS are to be followed.
- The wall structure must be designed to limit the deflection at the actual design wind load to no greater than L/120 in accordance with FBC Table 1604.3. Where framing and sheathing details are provided in these tables, this represents only the minimum tested or calculated materials for the required strength of attachment of the wall cladding. Primary structural building loads and capacity of the building framing is outside the scope of this table and must be designed and installed for the applicable wind, climate and occupancy loads as required by Code for the construction project.
- Allowable pressure (psf) (ASD) represents tested assembly ultimate pressure divided by safety factor of 2.
- To convert to Factored Design Resistance Pressure (psf) (LRFD), multiply Allowable Pressure (psf) (ASD) by 1.67.
- Vent Panels have 5/16" thick x 3/4" wide x 6-1/2" long cedar strips applied vertically to the back of panel 8" on center.

**ATTACHMENT 2: WIND PRESSURE AND WIND SPEED TABLES**

**User's Guide to Cedar Valley Shingle and Mansard panels Wind Pressure and Wind Speed Tables:**

The Cedar Valley Shingle and Mansard panels wind pressures and wind speed conversion tables have been developed to assist users in determining appropriate installation details for a range of wall construction components, building dimension plans, and site and environmental conditions.

Wind speed conversion tables have been prepared following design methodology of ASCE7-22, Ch. 30.3, for low-rise buildings with maximum height of 60 ft, for enclosed buildings with topographic and elevation factors set to unity. These settings are typical of many installations, and consistent with the prescriptive approach used in FBC-R Table R301.2(2). All conditions must be consistent with Table Notes 1-14 and the details within the wind speed conversion tables to be considered valid. If the actual site, building dimension or climatic conditions (including the given variables) differ from those prescribed, the allowable pressure values may be used to calculate adjusted wind speed limits.

For building heights over 60 ft, the Allowable Pressure (ASD) values listed in the wind uplift tables may be used by a licensed design professional to calculate ultimate wind speed and/or allowable height, for the given Cedar Valley product installation detail and building project conditions.

At any building height, when the Allowable Pressure (ASD) has been pre-determined by the designer or building official, the user only needs to check that the installation detail is shown as capable of that pressure or greater.

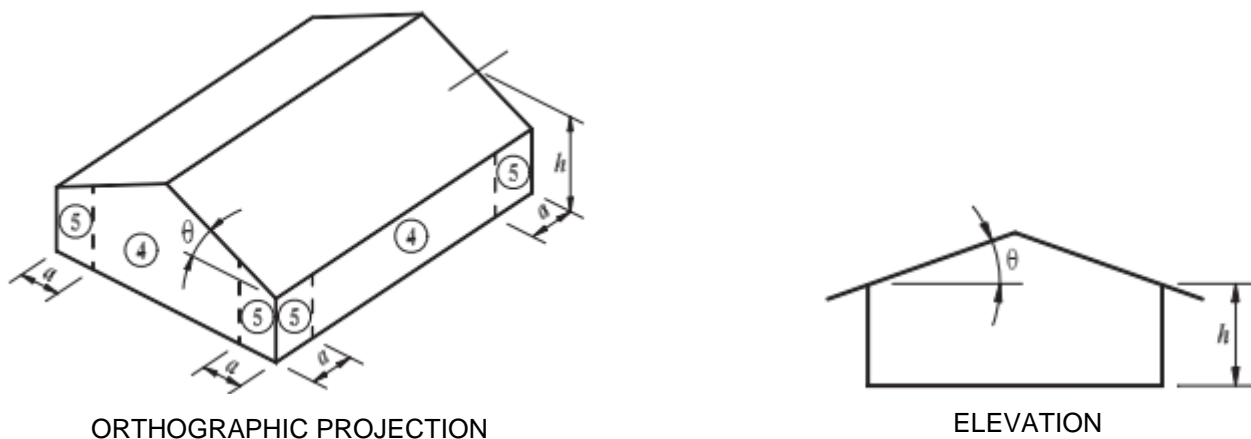

$a = 10\%$  of least horizontal dimension or  $0.4h$ , whichever is smaller, but not less than either  $4\%$  of least horizontal dimension or 3 ft (0.9 m).

Exception: For buildings with  $\theta = 0^\circ$  to  $7^\circ$  and a least horizontal dimension greater than 300 ft (90 m), dimension  $a$  shall be limited to a maximum of  $0.8h$ .

$h =$  Mean roof height, in ft (m), except that eave height shall be used for  $\theta \leq 10^\circ$ .

$\theta =$  Angle of plane of roof from horizontal, in degrees.

**Figure 1.** Wind Pressure Diagrams as Represented in ASCE7-22 for use in conjunction with Tables 2, 3, 4.



**Table 2: Maximum Wind Speeds of Wall Cladding Installed at Various Building Heights and Exposure Categories – 2023 FBC Non-HVHZ<sup>1,2,3</sup>**

Assembly No. <sup>4</sup>	Allowable Pressure (psf) (ASD) <sup>5,6</sup>	Exposure Category <sup>7</sup>	ZONE 5 (CORNER) <sup>8</sup>							ZONE 4 (FIELD) <sup>8</sup>						
			Maximum Wind Speed V <sub>ult</sub> (mph)							Maximum Wind Speed V <sub>ult</sub> (mph)						
			Building Height (ft) <sup>9</sup>							Building Height (ft) <sup>9</sup>						
			15	20	25	30	40	50	60	15	20	25	30	40	50	60
1, 2	82.0	B	210	210	210	210	210	210	210	210	210	210	210	210	210	210
		C	210	210	206	201	196	191	188	210	210	210	210	210	210	208
		D	196	192	188	185	181	177	174	210	210	209	206	201	197	194
3	65.9	B	210	210	210	210	208	201	196	210	210	210	210	210	210	210
		C	194	188	184	181	175	171	168	210	209	205	201	195	190	187
		D	176	172	169	166	162	159	156	196	191	188	184	180	176	173
4	83.2	B	210	210	210	210	210	210	210	210	210	210	210	210	210	210
		C	210	210	207	203	197	192	189	210	210	210	210	210	210	210
		D	198	193	190	186	182	178	175	210	210	210	207	202	198	195
5	76.3	B	210	210	210	210	210	210	210	210	210	210	210	210	210	210
		C	209	203	198	194	189	184	181	210	210	210	210	210	205	201
		D	190	185	182	179	174	171	168	210	206	202	198	193	190	187

**Table 2 Notes**

- All component material and installation specifications listed in *ATTACHMENT 1: GENERAL ASSEMBLY DETAILS* must be followed to use this table.
- Table limiting heights and wind velocity values are for low-rise buildings of maximum 60 ft height, developed in accordance with ASCE7-22, Table 30.3-1. Design input values: G<sub>Cp</sub> = -1.4 (Zone 5) and -1.1 (Zone 4), G<sub>Cpi</sub> = 0.18, K<sub>zt</sub> = 1, K<sub>d</sub> = 0.85, K<sub>e</sub> = 1, I<sub>w</sub> = 1.0.
- The wall structure must be designed to limit the deflection at the design wind load to no greater than L/120 in accordance with FBC Table 1604.3.
- Further assembly details provided in *ATTACHMENT 3: ASSEMBLY DIAGRAMS* are to be followed.
- Allowable pressure (psf) (ASD) represents tested assembly ultimate pressure divided by safety factor of 2.
- To convert to Factored Design Resistance Pressure (psf) (LRFD), multiply Allowable Pressure (psf) (ASD) by 1.67.
- Wind exposure categories as defined in ASCE7-22, section 26.7.
- Wind speed conversion corresponds to the maximum Zone 4 and 5 pressure with effective area of 10 ft<sup>2</sup>. Table wind speeds are only valid under the design conditions stated. For other site conditions and/or building dimensions, designers can use the published Allowable Pressure (psf) (ASD) to determine allowable wind speeds with FBC-R Table R301.2(2) or calculations to FBC Ch 16.
- Interpolation not permitted. For heights in between those listed, use next highest height column.

**ATTACHMENT 3: ASSEMBLY DIAGRAMS**

Begins next page.





CEDAR VALLEY SHINGLE AND MANSARD EXTERIOR CLADDING  
 DETAILS OF 2023 FBC WIND LOAD RESISTANCE ASSEMBLIES

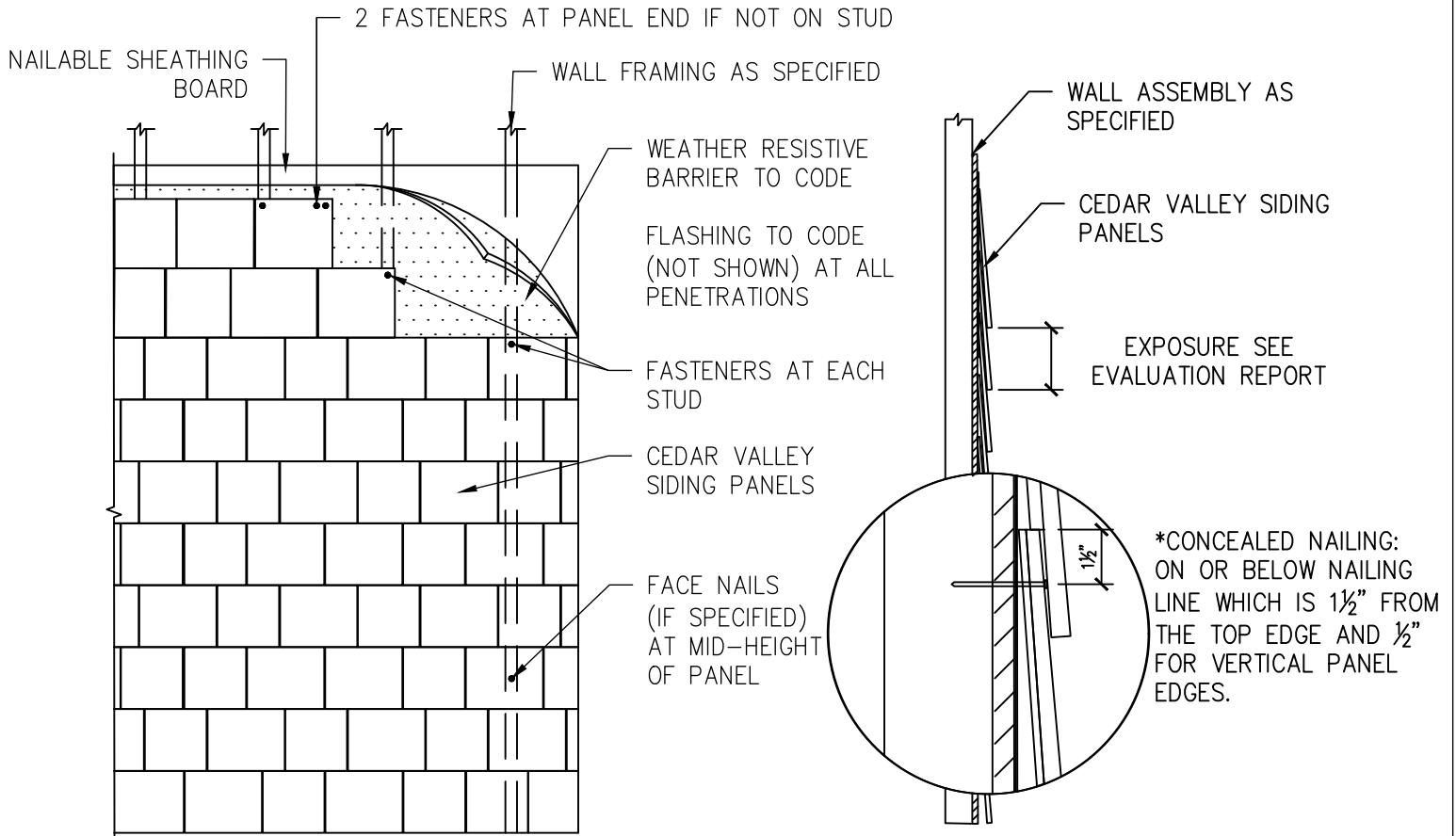

**A**  
 1 GENERAL SIDING INSTALLATION  
 ELEVATION VIEW NOT-TO-SCALE

**B**  
 1 SIDING INSTALLATION  
 SECTION VIEW NOT-TO-SCALE

DRAWING FOR ENGINEERING  
 EVALUATION REPORT – NOT  
 FOR USE AS CONSTRUCTION  
 DESIGN DOCUMENTS

COPYRIGHT ©2023 RESERVED. THESE PLANS AND DESIGNS ARE AT ALL TIMES THE PROPERTY OF BOCA ENGINEERING CO.  
 TO BE USED FOR THE PROJECT SHOWN. WRITTEN CONSENT IS REQUIRED FROM THE ENGINEER BEFORE ANY REPRODUCTION.

CLIENT: CEDAR VALLEY MANUFACTURING, INC	PROJECT: CEDAR VALLEY SHINGLE AND MANSARD EXTERIOR CLADDING PANELS	TITLE: SIDING WIND LOAD INSTALLATION DETAILS	0	2023/10/06	FOR PUBLICATION	CB
			REV	DATE	ISSUE	APP
			DRAWING NO. 5953-SK1		DWG SHEET 1 OF 3	
			DATE	OCTOBER 06, 2023		DES CB
					DRN TH	CHK CB



# CEDAR VALLEY SHINGLE AND MANSARD EXTERIOR CLADDING DETAILS OF 2023 FBC WIND LOAD RESISTANCE ASSEMBLIES

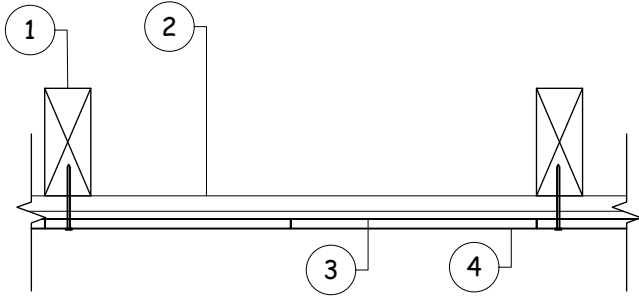

WOOD-FRAMED STUD & SHEATHING ASSEMBLY INTERIOR TO EXTERIOR	
1	NO.2 GRADE SPRUCE-PINE-FIR OR BETTER DIMENSIONED LUMBER @ MAX. 16" O.C. SEE EVALUATION REPORT.
2	SHEATHING FASTENED TO STUDS PER CODE, SEE ENGINEERING EVALUATION REPORT
3	WATER RESISTIVE BARRIER TO CODE
4	CEDAR VALLEY SIDING PANELS FASTENING PER ENGINEERING EVALUATION REPORT

**A**  
**2** CEDAR VALLEY SIDING OVER STUD WALL & PLYWOOD SHEATHING  
SECTION VIEW NOT-TO-SCALE

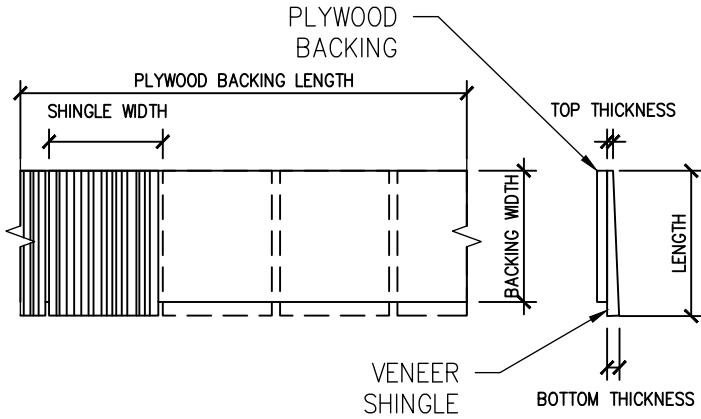

CEDAR VALLEY SIDING PANEL DIMENSIONS					
PRODUCT	SHINGLE			PLYWOOD BACKING	
	LENGTH (IN.)	WIDTH (IN.)	THICKNESS (IN.)	LENGTH (IN.)	HEIGHT (IN.)
COASTAL	6.8, 8 <sup>5</sup> / <sub>8</sub>	3 - 14	<sup>5</sup> / <sub>16</sub> - <sup>1</sup> / <sub>2</sub>	96	5.3, 7 <sup>1</sup> / <sub>8</sub>
VENT	8 <sup>5</sup> / <sub>8</sub>	3 - 14	<sup>5</sup> / <sub>16</sub>	96	7 <sup>1</sup> / <sub>8</sub>
MANSARD	15 <sup>1</sup> / <sub>2</sub>	3 - 14	<sup>3</sup> / <sub>8</sub>	96	14

**B**  
**2** GENERAL CLADDING PANEL COMPOSITION  
ELEVATION & SECTION VIEW NOT-TO-SCALE

DRAWING FOR ENGINEERING  
EVALUATION REPORT - NOT  
FOR USE AS CONSTRUCTION  
DESIGN DOCUMENTS

COPYRIGHT ©2023 RESERVED. THESE PLANS AND DESIGNS ARE AT ALL TIMES THE PROPERTY OF BOCA ENGINEERING CO. TO BE USED FOR THE PROJECT SHOWN. WRITTEN CONSENT IS REQUIRED FROM THE ENGINEER BEFORE ANY REPRODUCTION.



CLIENT: CEDAR VALLEY MANUFACTURING, INC	PROJECT: CEDAR VALLEY SHINGLE AND MANSARD EXTERIOR CLADDING PANELS	TITLE: SIDING WIND LOAD INSTALLATION DETAILS	0 REV	2023/10/06 DATE	FOR PUBLICATION ISSUE	CB APP
			DRAWING NO. 5953-SK1		DWG SHEET 2 OF 3	
			DATE OCTOBER 06, 2023		DES CB DRN TH CHK CB	



CEDAR VALLEY SHINGLE AND MANSARD EXTERIOR CLADDING  
DETAILS OF 2023 FBC WIND LOAD RESISTANCE ASSEMBLIES

LEGEND AND SYMBOLS

 — DETAIL NUMBER  
 — SHEET DRAWN

 — SECTION NUMBER  
 — SHEET DRAWN

TESTING AND CODE COMPLIANCE

1. THE SIDING PRODUCT ASSEMBLY SHOWN IS DESIGNED TO COMPLY WITH THE 8TH EDITION (2023) FLORIDA BUILDING CODE (FBC)
2. THE STRUCTURAL FRAMING AND SHEATHING SHALL BE DESIGNED AND ANCHORED TO PROVIDE LATERAL BRACING AND PROPERLY TRANSFER ALL LOADS TO THE STRUCTURE. FRAMING DESIGN AND INSTALLATION IS THE RESPONSIBILITY OF THE ENGINEER OR ARCHITECT OF RECORD FOR THE PROJECT OF INSTALLATION.
3. THESE DRAWINGS APPLY TO THE TESTING ASSEMBLY ONLY AND DO NOT IMPLY THAT THE SIGNATORY ENGINEER IS THE DESIGNER OF RECORD FOR ANY FUTURE CONSTRUCTION ON WHICH THEY ARE USED.
4. SOME NON-STRUCTURAL COMPONENTS NOT SHOWN AND DO NOT IMPACT STRENGTH FOR ATTACHMENT. TO BE INSTALLED PER CODE AND MAY INCLUDE: FLASHING, INTERIOR INSULATION, INTERIOR FINISH.

INSTALLATION

1. THE INSTALLATION DETAILS DESCRIBED ARE OF THE LABORATORY TESTED ASSEMBLY AND MAY NOT REFLECT ACTUAL CONDITIONS FOR A SPECIFIC SITE. IF SITE CONDITIONS DEVIATE FROM THE REQUIREMENTS DETAILED HEREIN, THE JOB ENGINEER OR ARCHITECT PREPARED SITE-SPECIFIC DOCUMENTS SHALL BE USED.

SHEATHING

1. WOOD-BASED STRUCTURAL SHEATHING:
  - 1.1. PLYWOOD – US DOC PS1-09 OR PS2-10 U.N.O.
  - 1.2. OSB – US DOC PS2-10 U.N.O.

FASTENERS

1. WOOD SCREWS TO CONFORM TO ASME B18.6.1 U.N.O.
2. SIDING NAILS TO CONFORM TO ASTM F1667.
3. ALL FASTENERS WITH CORROSION-RESISTANT GALVANIZED COATING.

FRAMING

1. WOOD FRAMING MIN. 2x4 S.G. 0.42, COMPLIANCE WITH US DOC PS20-05.

DRAWING FOR ENGINEERING  
EVALUATION REPORT – NOT  
FOR USE AS CONSTRUCTION  
DESIGN DOCUMENTS

COPYRIGHT ©2023 RESERVED. THESE PLANS AND DESIGNS ARE AT ALL TIMES THE PROPERTY OF BOCA ENGINEERING CO. TO BE USED FOR THE PROJECT SHOWN. WRITTEN CONSENT IS REQUIRED FROM THE ENGINEER BEFORE ANY REPRODUCTION.

CLIENT: CEDAR VALLEY MANUFACTURING, INC	PROJECT: CEDAR VALLEY SHINGLE AND MANSARD EXTERIOR CLADDING PANELS	TITLE: SIDING WIND LOAD INSTALLATION NOTES	0	2023/10/06	FOR PUBLICATION	CB
			REV	DATE	ISSUE	APP
			DRAWING NO. 5953-SK1		DWG SHEET 3 OF 3	DES CB
			DATE OCTOBER 06, 2023			DRN TH CHK CB